

MODEL : PK50

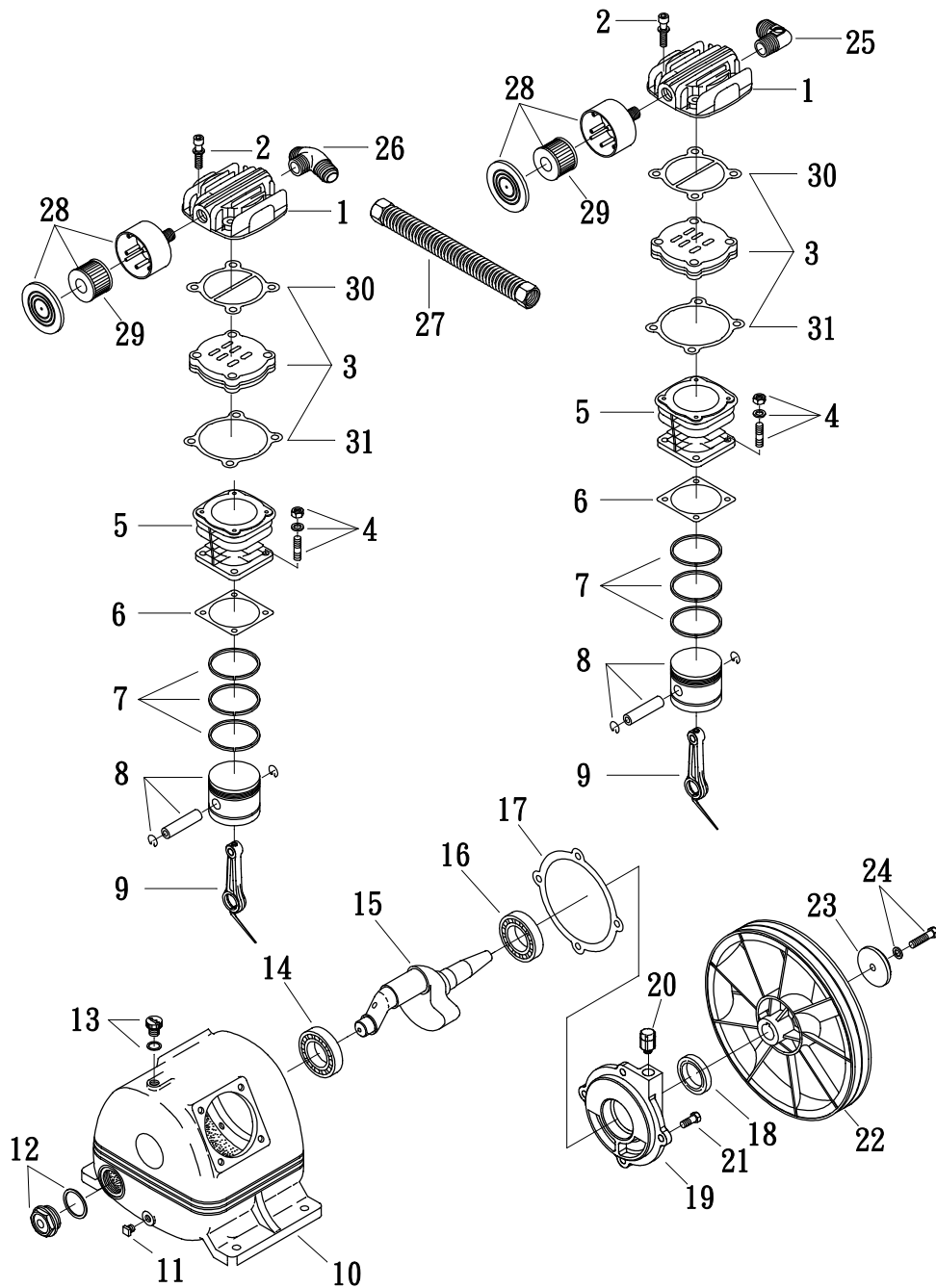

SPARE PARTS LIST

NO : MB-1905

| REF. NO. | DESCRIPTION | PART NO. | QTY. | REF. NO. | DESCRIPTION | PART NO. | QTY. |
|----------|--------------------------|----------------|------|----------|--------------------------|------------------|------|
| 1 | Cylinder head | 3101052 | 2 | 17 | Rear bearing seat gasket | 2G06-008 | 1 |
| 2 | Allen bolt set | 3B01-M06*040VW | 8 | 18 | Oil seal | 2N50-TC24*47*07 | 1 |
| 3 | In. & Ex. valve assembly | 3B13-K5051C | 2 | 19 | Rear bearing seat | 3311034 | 1 |
| 4 | Double head screw set | 3B11-001-A | 8 | 20 | Breathing cover | 2321008 | 1 |
| 5 | Cylinder | 3201036 | 2 | 21 | Hexagon bolt | 2B00-SM08*020 | 4 |
| 6 | Cylinder gasket | 2G04-002 | 2 | 22 | Pulley | 3PBF-105A124 | 1 |
| 7 | Piston ring set | 3B32-51N | 2 | 23 | Plate washer | 2B30-08*35*35 | 1 |
| 8 | Piston set | 3B31-51N | 2 | 24 | Hexagon bolt set | 3B00-SM08*035AV | 1 |
| 9 | Rod set | 3B33-H1048 | 2 | 25 | Exhaust elbow | 2N06-04T04H02T | 1 |
| 10 | Crankcase | 3301014 | 1 | 26 | Exhaust three way pipe | 2N09-04H04T04H1C | 1 |
| 11 | Oil draining plug | 2N33-001 | 1 | 27 | Exhaust tube set | 3B2-04*225 | 1 |
| 12 | Oil sight gauge set | 2303012A | 1 | 28 | Air filter set | 2140019A | 2 |
| 13 | Oil filling plug set | 2319003A | 1 | 29 | Filter element | 2142013 | 2 |
| 14 | Bearing | 2N35-6204 | 1 | 30 | Cylinder head gasket | 2G01-015C | 2 |
| 15 | Crankshaft & balancer | 3304038 | 1 | 31 | Valve seat gasket | 2G03-011H | 2 |
| 16 | Bearing | 2N35-6205Z | 1 | | | | |